

An Efficient Optimal Fractional Emotional Intelligent Controller for an AVR System in Power Systems

M. Moradi Zirkohi

Department of Electrical Engineering, Behbahan Khatam Alanbia University of Technology, Behbahan, Iran.

Received 18 February 2018; Revised 26 October 2018; Accepted 02 November 2018

*Corresponding author: moradi@bkatu.ac.ir (M. Moradi).

Abstract

In this paper, a high-performance optimal fractional emotional intelligent controller is proposed for an Automatic Voltage Regulator (AVR) in a power system using the Cuckoo optimization algorithm (COA). AVR is the main controller within the excitation system that preserves the terminal voltage of a synchronous generator at a specified level. The proposed control strategy is based upon brain emotional learning, which is a self-tuning controller so-called brain emotional learning-based intelligent controller (BELBIC), and is based on the sensory inputs and emotional cues. The major contribution of this paper is the use of the merits of the fractional order PID (FOPID) controllers; an FOPID controller is employed to formulate the stimulant input (SI) signal. This is a distinct advantage over the papers published in the literature, in which a PID controller has been reported to be used to generate the SI signal. Another remarkable feature of the proposed approach is that it is a model-free controller. The proposed control strategy can be a promising controller in terms of simplicity of design, ease of implementation, and less time-consumption. In addition, in order to enhance the performance of the proposed controller, its parameters are tuned by COA. COA is a novel advanced optimization algorithm proved to have a high efficiency. In order to design a BELBIC controller for an AVR system, a multi-objective optimization problem including overshoot, settling time, rise time, and steady-state error is formulated. The simulation studies confirm that the proposed controller, compared to the classical PID and FOPID controllers introduced in the literature, shows a superior performance regarding the model uncertainties. Having applied the proposed controller, the rise time and the settling time were found to be improved by 47% and 57%, respectively.

Keywords: *Brain Emotional Learning-based Intelligent Controller, Cuckoo Optimization Algorithm, Fractional Order PID, Automatic Voltage Regulator.*

1. Introduction

Unlike the DC generators, “alternators cannot be compounded to alter the voltage-load characteristic” [1]. Moreover, due to changes in the load power factor, the output voltage variations are increased. That is why the automatic voltage regulators (AVRs) are generally used with alternators [1]. In addition, for the damping power system oscillations, power system stabilizers (PSSs) can be used. The reference voltage of an AVR system is modified using the PSS output signal, and then AVR defines the primary voltage regulation of synchronous machines [2]. Therefore, The AVR system plays a decisive role in the industries to maintain the constant terminal voltage in the synchronous

generator under all the conditions. However, due to the high inductance of the generator field windings and load variation, achieving a desired response is difficult [3]. Therefore, it is important to improve the AVR performance and ensure a stable and efficient response to transient changes in terminal voltage. That is why an optimal controller in an AVR system is required [4]. So far, various control methods have been proposed for the AVR systems. One of the preferable controllers proposed in the literature is the proportional plus integral plus derivative (PID) controller because of its simple structure. Therefore, many optimization algorithms including particle swarm optimization (PSO) [5],

harmony search algorithm (HSA) [6], and artificial bee colony algorithm (ABC) [7, 8] have been employed to regulate the PID gains of the AVR systems.

Recently, in order to improve the performance of the PID controller, fractional calculus has played an important role in many control applications. The fractional order PID (FOPID) controllers are known “as a generalization of a standard PID controller” introduced by Podlubny [9, 10]. It should be noted that the FOPID controllers in many control applications have shown a “better control performance than a standard integer order PID controller due to extra degrees of freedom” [10]. Compared to the PID controller, the FOPID controller has two extra parameters [11]. This means that it is characterized by five parameters [12]. However, the selection of the values for its parameters is still a challenging task. So far, several intelligent techniques have been proposed for an efficient tuning of the FOPID controller. Such algorithms include Particle swarm optimization (PSO) [10, 13, 14], Genetic Algorithm (GA) [14, 15], fruit fly optimization algorithm [16], and Cuckoo Optimization Algorithm (COA) [17]. In the literature, it has been stated that the FOPID controller has been employed for controlling a practical AVR as well. Zhang [5] has suggested the PSO approach for the optimum design of the FOPID controller in the AVR system. The results obtained using this method have been compared with the conventional PID controller. Zhang et al. [7] have used the Artificial Bee Colony (ABC) algorithm to optimize the parameters of the FOPID controller for an AVR system. The results obtained have been compared with PSO and GA, indicating that the proposed controller has a better performance. Yingga et al. [12] have employed the Chaotic Ant Swarm (CAS) optimization algorithm to regulate the parameters of the FOPID controller. The results obtained have indicated that the proposed FOPID controller is robust to model uncertainties.

Recently, a new evolutionary algorithm called COA has been proposed [18]. The comparison of COA with the standard versions of PSO and GA have revealed the superiority of COA in terms of fast convergence and accuracy [18, 19]. Therefore, COA has been used for the optimization of the FOPID parameters for the AVR system [17]. In this state-of-the-art research work, it has been shown that the proposed optimized controller provides a more improved dynamic performance compared to the other existing techniques.

Despite the great efforts devoted to AVR control, many of the theoretical results cannot be directly applied to the practical AVR system. The reason is that this system includes model non-linearity and model uncertainties. Recently, intelligent techniques including neural networks [20] and fuzzy systems [21, 22] have been introduced to overcome these issues. The reason for the fact that in the academic filed the application of intelligent control has been increased is that they are model-free control methods [23]. This means that a perfect dynamic model is not required. Therefore, some researchers have employed intelligent techniques in order to control the AVR system. For example, in [24], the fuzzy controller has been used for the AVR system.

Recently, the brain emotional learning controller has been introduced as a new intelligent controller [25]. Brain emotional learning is based upon a computational model of a limbic system in the human brain [23]. Specifically, BELBIC “is essentially an action generation mechanism based on sensory inputs (SIs) and emotional cues (ECs)”, and the most interesting concept of BELBIC is the flexibility in definition of SI and EC depending on the control problem [25]. So far, BELBIC has been used in many industrial applications such as washing machines [26, 27], power system applications [27-30], aerospace launch vehicle [31], and micro-heat exchanger [32]. The mentioned papers have indicated that BELBIC has a good robustness and performance [33]. Since the parameters to be tuned in BELBIC are less than neural networks and fuzzy systems, BELBIC has a simple structure.

As mentioned earlier, most of the proposed controllers for AVR are based upon the optimization algorithms. It should be noted that “in real power systems, this search process takes a long time” [34]. In addition, by considering the structured and unstructured uncertainties, the dynamic behaviors of real power systems are different [34]. Therefore, the PID or FOPID controllers “optimized by off-line search algorithms may not have a good performance under these conditions” [34]. The main objective of this paper was to address these issues.

The main contribution of this work is to propose a novel emotional intelligent controller as the main controller of the AVR system, in which, to use the merits of the FOPID controllers, an FOPID controller is used to formulate the stimulant input signal. One advantage of the proposed controller is that it is a self-tuning controller. This means that depending on the operational conditions of the AVR system, its behavior is modified. The

second contribution of this work is that COA is employed to optimize the control design parameters and enhance the performance of the control system. Since the number of parameters of COA is less than the parameters used in the other meta-heuristic techniques, this fact results in a fast convergence of the BELBIC parameters. In order to design a BELBIC controller for an AVR system, a multi-objective optimization problem including the overshoot, settling time, rise time, and steady-state error was formulated.

To the best of our knowledge, this is the first time that this structure has been presented. This is a distinct advantage in comparison to the papers published in the literature. The great merit of the proposed control strategy is that it is superior to the fuzzy and neural network systems in terms of simplicity of design, ease of implementation, and less time-consumption. In addition, it is a model-free controller. This means that it does not require any information from the system dynamics. The performance of the proposed controller was compared with some PID and FOPID controllers introduced in the previous research works. Also uncertainties in the AVR parameters were taken into account to show the robustness of the proposed controller.

The remaining part of this paper is organized as what follows. In Section 2, the AVR system is described. In Section 3, the fractional PID controllers are briefly introduced. The description of the cuckoo search algorithm is discussed in Section 4. Section 5 briefly describes the brain emotional learning. In Section 6, the simulation results are presented. Finally, Section 7 concludes the paper.

2. AVR system model

“To maintain the terminal voltage magnitude at a constant specified level in synchronous generators, the AVR system is used” [3, 35]. The AVR system consists of four main components, namely amplifier, exciter, sensor, and generator [3]. “For mathematical modeling and the transfer function of the four components, these components must be linearized, which takes into account the major time constant and ignores the saturation or other non-linearities” [5]. From a practical viewpoint, by ignoring the saturation or other non-linearities, the PID and FOPID controllers may not give a good performance in practical applications. That is why in this work, a self-tuning controller called BELBIC was developed to deal with the uncertainties. The transfer function of the mentioned components can be represented as what follows [3, 5, 12].

The transfer function representation of amplifier is as follows:

$$G_A(s) = \frac{K_A}{1 + \tau_A s} \quad (1)$$

where, the amplifier gain (K_A) and time constant (τ_A) are given as $10 < K_A < 400$ and $0.02 < \tau_A < 0.1$.

The transfer representation of the exciter model is as follows:

$$G_E(s) = \frac{K_E}{1 + \tau_E s} \quad (2)$$

where, the exciter gain (K_E) and time constant (τ_E) are given as $10 < K_E < 400$ and $0.5 < \tau_E < 1$, respectively.

The transfer function representation of the generator is given as follows:

$$G_G(s) = \frac{K_G}{1 + \tau_G s} \quad (3)$$

where, the exciter gain (K_G) and time constant (τ_G) are given as $0.7 < K_G < 1$ and $1 < \tau_G < 2$, respectively.

The transfer function representation of the sensor model is as follows:

$$G_s(s) = \frac{K_s}{1 + \tau_s s} \quad (4)$$

where, the feedback gain (K_s) and time constant (τ_s) are given as $0.9 < K_s < 1$ and $0.001 < \tau_s < 0.06$, respectively.

The block diagram of the AVR system components including BELBIC is shown in figure 1. Figure 2 shows the voltage response of the AVR system without considering the controller. As seen, it exhibits high oscillations with $M_p = 65.43\%$, $t_p = 0.75s$, $t_s = 6.97s$, $t_r = 0.42s$. In the steady state condition, the system terminal voltage V_t deviates from the nominal value of 0.01. In a power system with a high operating voltage, this response is completely undesirable [36]. For this reason, a controller is required to be incorporated in the AVR system.

3. Fractional PID controller

The “fractional calculus is a name of the theory of integrations and derivatives of arbitrary order” [37]. The FOPID controller is a fractional order structure, which provides more flexibility compared with the PID controller [38]. So far, FOPID has been applied for control purposes [3, 7, 12, 37].

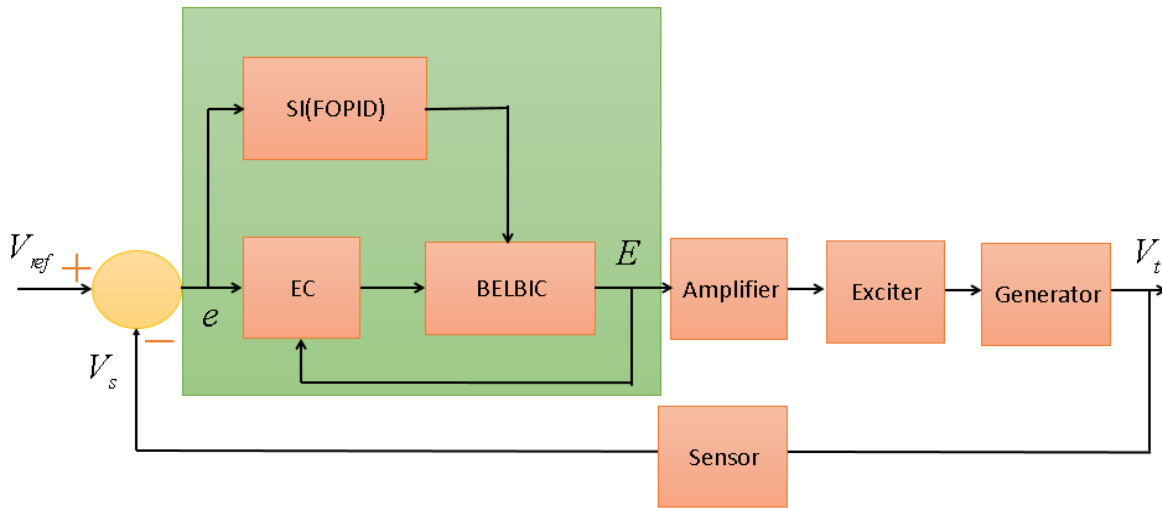

Figure 1. Block diagram of an AVR system with controller.

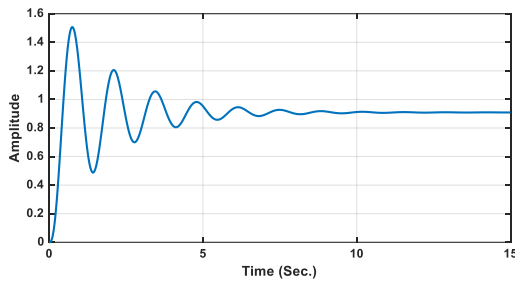

Figure 2. Step response of an AVR system without controller.

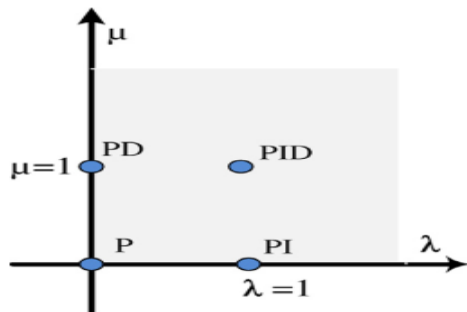

Figure 3. Graphical representation of FOPID controller [17].

Generally, the FOPID controller is given as:

$$G_{FOPID}(s) = K_p + \frac{K_i}{s^\lambda} + K_D s^\mu \quad (5)$$

where, K_p, K_i and K_D are the proportional, integral, and derivative gains, respectively. In the meanwhile, λ is the fractional orders of the integral part and μ is the fractional orders of the derivative part of the FOPID controller. Figure 3 shows the graphical representation of the FOPID controller. As seen, depending upon the values for λ and μ , the conventional P, PI, PD, and PID controllers can be obtained from the FOPID controller.

4. Cuckoo optimization algorithm (COA)

Recently, a novel evolutionary algorithm called COA has been introduced, “which is inspired by the life of cuckoo” [18, 39]. “Like the other evolutionary algorithms, COA starts with an initial population of cuckoos called habitat” [18]. To solve the optimization problem, a candidate habitat matrix of size $N_p \times N_{var}$ must be generated. Meanwhile, N_p “is the maximum number of cuckoos that can live at the same time” and N_{var} is the number of parameters to be optimized. Further, “each cuckoo laying eggs within a distance called the egg laying radius (ELR) is defined based upon the following equation” [18, 40]:

$$ELR = \alpha \times \frac{\text{Number of current cuckoo's eggs}}{\text{Total number of eggs}} \times (\text{var}_{hi} - \text{var}_{low}) \quad (6)$$

where, var_{hi} is the upper limit and var_{low} is the lower limit of variables. In the meanwhile, α is an integer, defined to handle the maximum value of ELR. “Each cuckoo starts laying eggs randomly in some other host bird’ nests within her ELR” [41]. The new egg-laying process can be defined as follows:

$$X_{next} = X_{current} + F(X_{goal} - X_{current}) \quad (7)$$

where, X and F are the position and the motion coefficient, respectively. The pseudo-code of the COA algorithm can be found as in [18]. To evaluate the performance of the AVR system, an objective function must be defined. Therefore, in this paper, a time domain performance criterion is defined as [5]:

$$J = (1 - e^{-\beta})(M_p + e_{ss}) + e^{-\beta}(t_s - t_r) \quad (8)$$

where, β is the weighting factor, and M_p, e_{ss}, t_s , and t_r denote the maximum overshoot, steady state error, settling time, and rise time, respectively. It should be noted that in this objective function, the time response specifications are included.

5. Brain emotional learning-based intelligent controller (BELBIC)

As shown in figure 4, “the main components of the limbic system involved in emotional processes are amygdala, orbitofrontal cortex, thalamus, sensory cortex, hypothalamus, and hippocampus” [30]. learning [42]. This model is shown in figure 5. The emotional learning takes place mostly in the amygdala. In fact, “the amygdala is responsible for long-term memory and emotional stimuli. It receives signals from the sensory cortex and is in interaction with the orbitofrontal cortex” [23].

As seen in figure 5, BELBIC has two states for each sensory input. Figure 6 shows the computational model of emotional learning in more details as well. As seen in this figure, the vector S shows the stimuli inputs to the system. There is a node for each stimulus S . Suppose the i^{th} sensory input as s_i .

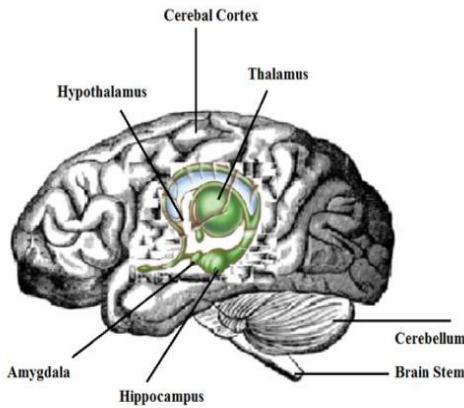

Figure 4. The limbic system of the brain [28].

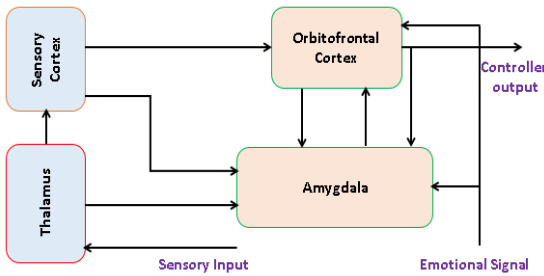

Figure 5. Block diagram of the presented computational model of human brain learning mechanism.

As seen, A_{th} is an input to the amygdala part, which is the maximum of stimuli inputs (SIs), given by [43].

$$A_{th} = V_{th}(\max(S_i) = S_{th}) \quad (9)$$

In the meanwhile, the weight V_{th} is updated according to the following equation:

$$\Delta V_{th} = k_{th}(\max(0, S_i(EC - A_{th}))) \quad (10)$$

where, k_{th} is the learning step. In addition, the amygdala and orbitofrontal cortex outputs are, respectively, given by:

$$A_i = S_i V_i \quad (11)$$

$$O_i = S_i W_i \quad (12)$$

where, V_i and W_i are two states that are updated according to the following equations [43]:

$$\Delta V_{th} = k_1(\max(0, S_i(EC - \sum_i A_i))) \quad (13)$$

$$\Delta W_i = k_2(S_i(E' - \sum_i A_i)) \quad (14)$$

where, k_1 and k_2 are the learning steps in the amygdala and orbitofrontal cortex, respectively [44].

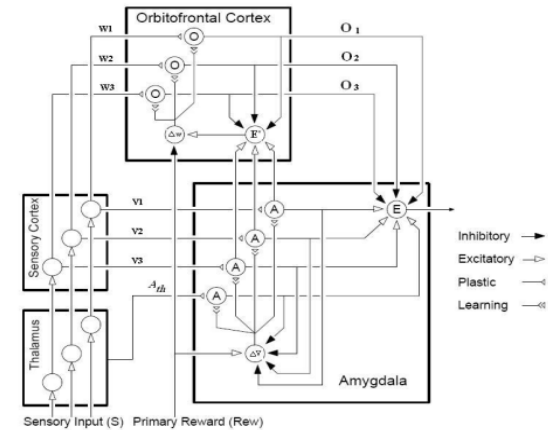

Figure 6. Graphical depiction of the BEL process [42].

Eventually, the model outputs (MOs) or output nodes E and E' are given as:

$$E = \sum_i A_i + A_{th} - \sum_i O_i \quad (15)$$

$$E' = \sum_i A_i - \sum_i O_i \quad (16)$$

It should be noted that the weights V in Eq. (13) cannot be decreased. It can be concluded that the information in the amygdala part is not forgotten. In this paper, to improve the performance of the proposed approach, the thalamus is also modeled by Eq. (10). As a result, different learning steps are considered in Eqs. (10) and (13).

Table 1. Searching range of parameters.

Parameter	k_p	k_i	k_d	λ	μ	k_1	k_2	k_{th}	a_{c_1}	a_{c_2}	a_{c_3}	m_a	m_o	m_{th}
Min. value	0	0	0	.001	.001	0	0	0	0	0	0	0	0	0
Max. value	2	1	1	2	2	1	1	5	40	40	40	1	1	1

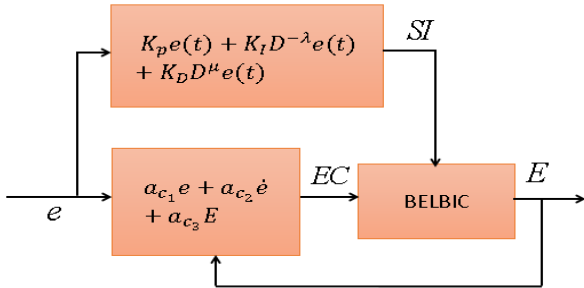

Figure 7. Block diagram of the proposed structure.

6. Proposed BELBIC

“The sensory input (SI) is a kind of control signal that in BELBIC is reinforced or punished based on an emotional cue so it should be chosen as a function of error, just like a PID controller” [32]. In most of the published papers, the researchers have utilized the PID controller to form the stimulant input signal [32, 34]. For simplicity, this is named as PID-BELBIC. In the present paper, as a novelty, owing to the value and high performance of self-tuning FOPID controllers, a FOPID controller is employed to formulate the stimulant input signal, as given by (17). For simplicity, this is named as FOPID-BELBIC.

$$SI(s) = (K_p + \frac{K_i}{s^\lambda} + K_D s^\mu) E(s) \tag{17}$$

where, K_p, K_i , and K_D are the proportional, integral, and derivative gains, respectively. In the meantime, $\lambda > 0$ and $\mu > 0$ are not integers. The stimulant input signal in the time domain is:

$$SI(t) = K_p e(t) + K_i D^{-\lambda} e(t) + K_D D^\mu e(t) \tag{18}$$

In addition, the emotional signal (EC) generally must show the closed-loop system performance. Therefore, EC “can be written as a weighted combination of primary/secondary objectives in the application domain”, as follows [34]:

$$EC = a_{c_1} e + a_{c_2} \dot{e} + a_{c_3} E \tag{19}$$

where, E is given in Eq. (15) and e is the difference between the reference voltage and measured output voltage, namely $e = V_{ref} - V_s$. In the meanwhile, a_{c_1}, a_{c_2} , and a_{c_3} are the weight coefficients to be determined. The block diagram of the proposed structure is shown in figure 7.

7. Simulation results and discussion

In this section, the proposed controller was tested in controlling the AVR system.

To this end, to evaluate the performance and efficacy of the proposed controller, a practical high order automatic voltage regulator was considered with the following specifications:

$$K_A = 10, \tau_A = 0.1, K_E = 1, \tau_E = 0.4, K_G = 1, \tau_G = 1, K_s = 1, \tau_s = 0.01.$$

The block diagram of the control system is presented in figure 1. The number of parameters to be optimized by COA is 14, namely

$$k_p, k_i, k_d, \lambda, \mu, k_1, k_2, k_{th}, a_{c_1}, a_{c_2}, a_{c_3}, m_a, m_o \text{ and}$$

m_{th} . Note that m_a, m_o and m_{th} are the initial conditions of the memory used in (13), (14), and (10), respectively. In addition, the range of these parameters are given in table 1. Further, the parameters of COA are given as the maximum number of eggs for each cuckoo, 10; minimum number of eggs, 5; maximum number of cuckoos that live at the same time, 20; $\alpha = 5$ and $F = 9$. The maximum number of iterations was also set to 50 as a stopping criterion. In the objective function, β was set to 1.5. In our simulations, two scenarios were conducted to confirm the effectiveness of the proposed approach.

Scenario 1: In this case, parametric uncertainties were not considered. Both FOPID-BELBIC and PID-BELBIC were optimized. As a result of applying COA, the step responses of AVR are depicted in figure 8. As seen, the performance of the proposed controller (FOPID-BELBIC) was better than PID-BELBIC. One reason is that the number of parameters to be tuned in FOPID-BELBIC is 14, whereas the number of parameters to be tuned in PID-BELBIC is 12. FOPID-BELBIC has the advantage over the PID-BELBIC in that it has greater degrees of freedom in the controller parameters. These extra degrees of freedom can help to enhance the performance of the proposed approach. To have a better comparison, the values for the performance criteria for different controllers are summarized in table 2. The results obtained confirm that FOPID-BELBIC has a better performance in terms of all four indices. Figure 9 shows the convergence of

objective function at each generation. As seen, COA is well-convergent.

Table 3. Comparative performance of the controllers.

Type of controller	k_p	k_i	k_d	λ	μ	$M_p\%$	t_s	t_r	e_{ss}
MOEO-FOPID [10]	2.9737	0.9089	0.5383	1.1446	1.3462	3.2038	0.1800	0.1300	0
CS-FOPID [17]	2.515	0.1629	0.388	0.97	1.38	0	0.4507	0.1042	0

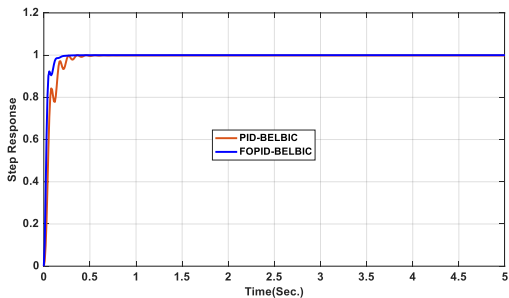

Figure 8. Step response of the AVR system using FOPID-BELBIC and PID-BELBIC.

Table 2. Comparison of FOPID-BELBIC and PID-BELBIC.

Type of controller	$M_p\%$	t_s	t_r	e_{ss}
FOPID-BELBIC	0	0.11	0.19	0
PID-BELBIC	0	0.26	0.36	0.0018

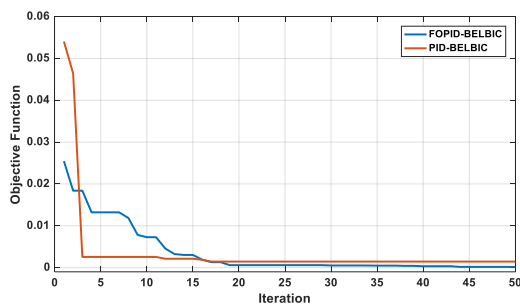

Figure 9. Objective function versus iteration.

It was observed that COA converged to 0.0001 in an around 19 iterations. In addition, the corresponding control parameter trajectories of SI parameters regarding the optimization algorithms is shown in figure 10, which indicates the convergence of the solution. To further demonstrate the effectiveness of the proposed FOPID-BELBIC, we gave the comparative performance of FOPID-BELBIC with different optimized FOPID controllers recently published in the literature such as MOEO-FOPID [10] and CS-FOPID [17]. The results obtained are given in table 3 and the corresponding step response is also shown in figure 11. According to the presented results, the results obtained indicate that the AVR system exhibits a better performance, as compared

with the other well-known controllers available in the literature.

Scenario 2: In this case, to test the robustness and powerfulness of the proposed controller, parametric uncertainties were considered. To save space, the uncertainties of the AVR model were given in terms of variations in the exciter generator. The variation range of the time constant was chosen to be $\pm 50\%$ of its nominal value with a 25% step size.

The results obtained are depicted in figure 12. As can be observed in this figure, the deviation of response curves. ($\pm 50\%$ and $\pm 25\%$) from the nominal response for the selected time constant parameter is within a small range. This can ensure the robustness of the proposed controller against such large variations. To have a better view, the step responses of the AVR system by considering 50% deviation in exciter generator as a result of applying proposed controller and MOEO-FOPID/PID are shown in figure 13. As seen, the proposed controller gives a better response. The system response using BELBIC is rather faster with less overshoot, even in the face of uncertainty. To sum up, from Scenarios 1 and 2, it can be concluded that the proposed controller outperforms others FOPID controllers with parameter variation in the AVR model.

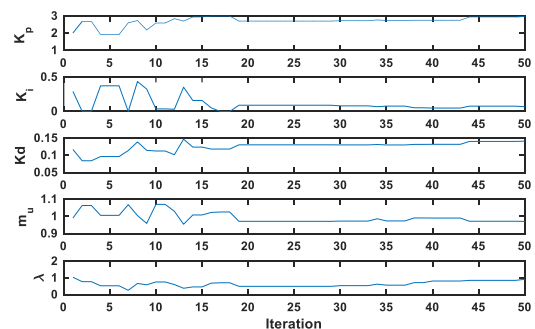

Figure 10. Corresponding control parameter trajectories of SI parameters versus iteration.

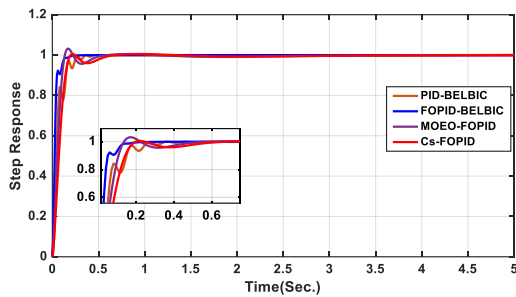

Figure 11. Comparison of unit step response of AVR system with different controllers.

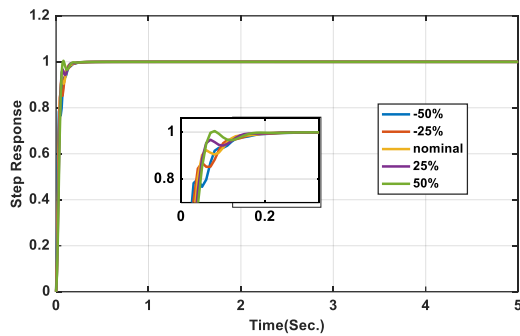

Figure 12. Comparison of unit step response of AVR system by considering uncertainty in exciter.

8. Conclusion

In this paper, a self-tuning controller based on brain emotional learning has been presented. The proposed approach involves an FOPID controller to generate an SI signal. This is the unique feature of the proposed controller. Application of this method to a practical AVR system shows that the developed control scheme outperforms the PID and FOPID controllers. To enhance the performance of control system, COA was used to tune the control design parameters. In addition, to show the robustness of the proposed controller, model uncertainties were also considered.

The simulation results confirmed that, compared to the PID and FOPID controllers, the proposed controller had more robust stability and performance characteristics. Having applied the proposed controller, compared to PID-BELBIC, the rise time and settling time were improved by about 47% and 57%, respectively. In addition, compared to the CS-FOPID method presented in [17], the settling time was improved by about 75%.

In particular, the proposed scheme could be a promising controller in terms of simplicity of design, ease of implementation, and less time-consumption. It is worthy of note that from the simulation results it could be concluded that the theoretical results obtained had a potential in applications.

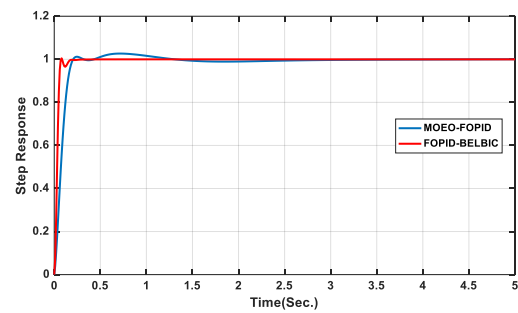

Figure 13. Step response of proposed controller and MOEO-PID/FOPID by considering uncertainty in exciter.

The practical implication of the proposed method is a part of our future works.

9. Acknowledgment

The author gratefully appreciates the support of the Behbahan Khatam Alanbia University of Technology.

References

- [1] Keljik, J., (2013), Electricity 3: power generation and delivery, Nelson Education.
- [2] Milano, F., (2010), Power system modelling and scripting, Springer Science & Business Media.
- [3] Sahib, M. A. (2015). A novel optimal PID plus second order derivative controller for AVR system. Engineering Science and Technology, an International Journal, vol. 18, no. 2, pp. 194-206.
- [4] BINGUL, Z., &KARAHAN, O. (2018). A Novel Performance Criterion Approach to Optimum Design of PID Controller Using Cuckoo Search Algorithm for AVR System. Journal of the Franklin Institute, vol. 355, no. 13, pp. 5534-5559.
- [5] Gaing, Z.-L. (2004). A particle swarm optimization approach for optimum design of PID controller in AVR system. IEEE transactions on energy conversion, vol. 19, no. 2, pp. 384-391.
- [6] Sambariya, D., &Paliwal, D., (2016), Optimal design of PIDA controller using harmony search algorithm for AVR power system, Power Systems (ICPS), 2016 IEEE 6th International Conference on, IEEE, pp. 1-6.
- [7] ZHANG, D.-L., Ying-Gan, T., &Xin-Ping, G. (2014). Optimum design of fractional order PID controller for an AVR system using an improved artificial bee colony algorithm. Acta Automatica Sinica, vol. 40, no. 5, pp. 973-979.
- [8] Gozde, H., &Taplamacioglu, M. C. (2011). Comparative performance analysis of artificial bee colony algorithm for automatic voltage regulator (AVR) system. Journal of the Franklin Institute, vol. 348, no. 8, pp. 1927-1946.

- [9] Polubny, I. (1999). Fractional-order systems and $PI\lambda D\mu$ controller. *IEEE Trans. Automatic Control*, vol. 44, no., pp. 208-214.
- [10] Zeng, G.-Q., et al. (2015). Design of fractional order PID controller for automatic regulator voltage system based on multi-objective extremal optimization. *Neurocomputing*, vol. 160, no., pp. 173-184.
- [11] Chen, Z., et al. (2014). Design of a fractional order PID controller for hydraulic turbine regulating system using chaotic non-dominated sorting genetic algorithm II. *Energy Conversion and Management*, vol. 84, no., pp. 390-404.
- [12] Tang, Y., et al. (2012). Optimum design of fractional order $PI\lambda D\mu$ controller for AVR system using chaotic ant swarm. *Expert Systems with Applications*, vol. 39, no. 8, pp. 6887-6896.
- [13] Cao, J.-Y., &Cao, B.-G., (2006), Design of fractional order controllers based on particle swarm optimization, *Industrial Electronics and Applications*, 2006 1ST IEEE Conference on, IEEE, pp. 1-6.
- [14] Elyasigomari, V., et al. (2015). Cancer classification using a novel gene selection approach by means of shuffling based on data clustering with optimization. *Applied Soft Computing*, vol. 35, no., pp. 43-51.
- [15] Cao, J.-Y., Liang, J., &Cao, B.-G., (2005), Optimization of fractional order PID controllers based on genetic algorithms, *Machine Learning and Cybernetics*, 2005. Proceedings of 2005 International Conference on, IEEE, pp. 5686-5689.
- [16] Sheng, W., &Bao, Y. (2013). Fruit fly optimization algorithm based fractional order fuzzy-PID controller for electronic throttle. *Nonlinear Dynamics*, vol. 73, no. 1-2, pp. 611-619.
- [17] Sikander, A., et al. (2018). A novel technique to design cuckoo search based FOPID controller for AVR in power systems. *Computers & Electrical Engineering*, vol. 70, no. 1, pp. 261-274.
- [18] Rajabioun, R. (2011). Cuckoo optimization algorithm. *Applied soft computing*, vol. 11, no. 8, pp. 5508-5518.
- [19] Lashkari, M., &Moattar, M. (2017). Improved COA with Chaotic Initialization and Intelligent Migration for Data Clustering. *Journal of AI and Data Mining*, vol. 5, no. 2, pp. 293-305.
- [20] Singh, P., et al., (2017), Sliding Mode Control of Uncertain Nonlinear Discrete Delayed Time System Using Chebyshev Neural Network. *Advances in Computer and Computational Sciences*, Springer, pp. 527-540.
- [21] Zirkohi, M. M., Kumbasar, T., &Lin, T. C. (2017). Hybrid Adaptive Type-2 Fuzzy Tracking Control of Chaotic Oscillation Damping of Power Systems. *Asian Journal of Control*, vol. 19, no. 3, pp. 1114-1125.
- [22] Hamza, M. F., Yap, H. J., &Choudhury, I. A. (2017). Recent advances on the use of meta-heuristic optimization algorithms to optimize the type-2 fuzzy logic systems in intelligent control. *Neural Computing and Applications*, vol. 28, no. 5, pp. 979-999.
- [23] Khorashadizadeh, S., &Mahdian, M., (2016), Voltage tracking control of DC-DC boost converter using brain emotional learning, *Control, Instrumentation, and Automation (ICCIA)*, 2016 4th International Conference on, IEEE, pp. 268-272.
- [24] Priyambada, S., Sahu, B. K., &Mohanty, P. K., (2015), Fuzzy-PID controller optimized TLBO approach on automatic voltage regulator, 2015 International Conference on Energy, Power and Environment: Towards Sustainable Growth (ICEPE), pp. 1-6.
- [25] Lucas, C., Shahmirzadi, D., &Sheikholeslami, N. (2004). Introducing BELBIC: brain emotional learning based intelligent controller. *Intelligent Automation & Soft Computing*, vol. 10, no. 1, pp. 11-21.
- [26] Lucas, C., Milasi, R. M., &Araabi, B. N. (2006). Intelligent modeling and control of washing machine using locally linear neuro-fuzzy (llnf) modeling and modified brain emotional learning based intelligent controller (BELBIC). *Asian Journal of Control*, vol. 8, no. 4, pp. 393-400.
- [27] Sheikholeslami, N., et al. (2006). Applying brain emotional learning algorithm for multivariable control of HVAC systems. *Journal of Intelligent & Fuzzy Systems*, vol. 17, no. 1, pp. 35-46.
- [28] Qutubuddin, M., &Yadaiah, N. (2017). Modeling and implementation of brain emotional controller for Permanent Magnet Synchronous motor drive. *Engineering Applications of Artificial Intelligence*, vol. 60, no., pp. 193-203.
- [29] Dehkordi, B. M., et al. (2011). Sensorless speed control of switched reluctance motor using brain emotional learning based intelligent controller. *Energy Conversion and Management*, vol. 52, no. 1, pp. 85-96.
- [30] Ale Aghaei, S., Lucas, C., &Amiri Zadeh, K. (2012). Applying Brain Emotional Learning Based Intelligent Controller (Belbic) to Multiple-Area Power Systems. *Asian Journal of Control*, vol. 14, no. 6, pp. 1580-1588.
- [31] Mehrabian, A. R., Lucas, C., &Roshanian, J. (2006). Aerospace launch vehicle control: an intelligent adaptive approach. *Aerospace Science and technology*, vol. 10, no. 2, pp. 149-155.
- [32] Rouhani, H., et al. (2007). Brain emotional learning based intelligent controller applied to neurofuzzy model of micro-heat exchanger. *Expert Systems with Applications*, vol. 32, no. 3, pp. 911-918.
- [33] Ravi, R., &Mija, S., (2014), Design of brain emotional learning based intelligent controller (BELBIC) for uncertain systems, *Advanced Communication Control and Computing Technologies*

(ICACCCT), 2014 International Conference on, IEEE, pp. 1089-1093.

[34] Khalghani, M. R., &Khooban, M. H. (2014). A novel self-tuning control method based on regulated bi-objective emotional learning controller's structure with TLBO algorithm to control DVR compensator. *Applied Soft Computing*, vol. 24, no. 2, pp. 912-922.

[35] Sarker, J., &Goswami, S. (2016). Optimal Location of Unified Power Quality Conditioner in Distribution System for Power Quality Improvement. *International Journal of Electrical Power & Energy Systems*, vol. 83, no. 1, pp. 309-324.

[36] Chatterjee, S., &Mukherjee, V. (2016). PID controller for automatic voltage regulator using teaching-learning based optimization technique. *International Journal of Electrical Power & Energy Systems*, vol. 77, no. 1, pp. 418-429.

[37] Das, S., (2008), *Functional fractional calculus for system identification and controls*, Springer-Verlag, Berlin, Heidelberg.

[38] Zamani, M., et al. (2009). Design of a fractional order PID controller for an AVR using particle swarm optimization. *Control Engineering Practice*, vol. 17, no. 12, pp. 1380-1387.

[39] Jadidi, Z., Muthukkumarasamy, V., &Sithirasanen, E., (2013), Metaheuristic algorithms based flow anomaly detector, *Communications (APCC)*, 2013 19th Asia-Pacific Conference on, IEEE, pp. 717-722.

[40] Shokri-Ghaleh, H., &Alfi, A. (2014). Optimal synchronization of teleoperation systems via cuckoo optimization algorithm. *Nonlinear Dynamics*, vol. 78, no. 4, pp. 2359-2376.

[41] Balochian, S., &Ebrahimi, E. (2013). Parameter optimization via cuckoo optimization algorithm of fuzzy controller for liquid level control. *Journal of Engineering*, vol. 2013, no. 1, pp. 123-128.

[42] Morén, J., &Balkenius, C. (2000). A computational model of emotional learning in the amygdala. *From animals to animats*, vol. 6, no. 1, pp. 115-124.

[43] Markadeh, G., et al. (2011). Speed and flux control of induction motors using emotional intelligent controller. *IEEE Transactions on Industry Applications*, vol. 47, no. 3, pp. 1126-1135.

[44] Jafari, E., et al. (2013). Designing an emotional intelligent controller for IPFC to improve the transient stability based on energy function. *Journal of Electrical Engineering and Technology*, vol. 8, no. 3, pp. 478-489.